

Thank you for purchasing the CMT Enlock Jig. This jig will simplify joinery in your shop, and on the job site.

Please read the instructions thoroughly before using the Enlock Jig.

Router requirements

A 1 hp or larger router will easily handle the Enlock's workload. Both bits available for the Enlock are 1/4-in. shank. The Enlock jig uses pattern-style dovetail bits, so it is not necessary for you to have guide bushings for your router. Be certain to unplug the router whenever changing bits or making adjustments to the router.

Exploded view

ENLOCK JOINING SYSTEM CMT-ENLOCK1

Refer to figure 1:

- | | | | |
|----|------------------------------|----|-----------------------------|
| 1 | Top plate (1 pc.) | 8 | Cam clamp handle (1 pc.) |
| 2 | End stops (2 pcs.) | 9 | Cam (2 pcs.) |
| 2a | Slide block (2 pcs.) | 10 | Clamp screws (2 pcs.) |
| 2b | End stop knob (2 pcs.) | 11 | Cam screws (2 pcs.) |
| 3 | Front plate (1 pc.) | 12 | Clamping rail (1 pc.) |
| 4 | Clamp extension arm (1 pc.) | 13 | Spring (2 pcs.) |
| 5 | Mitre plate screw (1 pc.) | 14 | Mitre plate (1 pc.) |
| 6 | Cam clamp end block (2 pcs.) | 15 | Support foot (2 pcs.) |
| 7 | Cam clamp bar (1 pc.) | 16 | Support foot screw (4 pcs.) |
| | | 17 | Top plate screw (4 pcs.) |

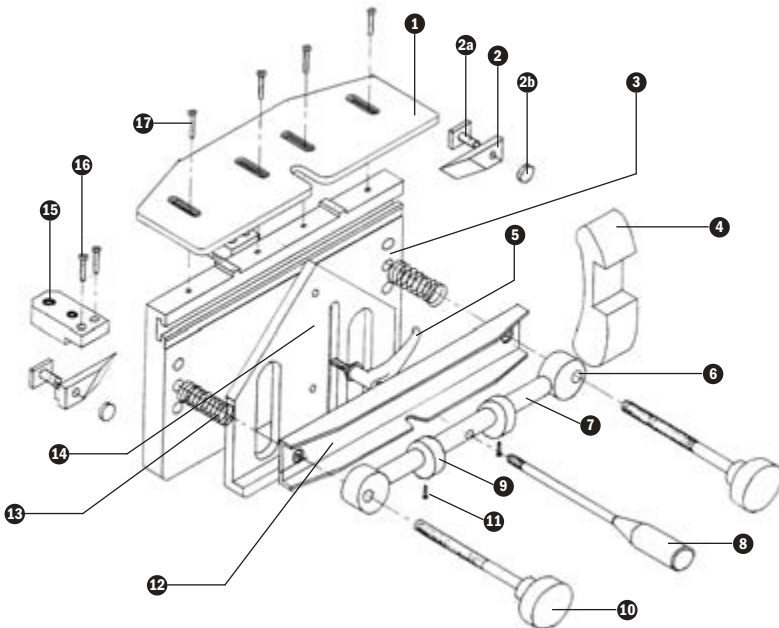

Understanding The Enlock Jig Dovetail keys and bits

Two sizes of dovetail keys are available for the Enlock. For material from 5/8-in. to 7/8-in. thick use the Enlock10 keys. For material from 7/8-in. to 1-3/8-in. thick use the Enlock15 keys. A sample bag of Enlock10 keys, and the matching solid carbide dovetail bit, are included with the Enlock Jig. Enlock15 keys and the matching dovetail bit are available from your CMT dealer.



When the cap is forced into the key by being tapped in with a mallet, the expansions pins on the bottom of the cap force the key to expand, securing it in the dovetail socket.

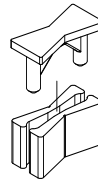

1. Dovetail sockets

The dovetail bits produce a dovetail socket, centered on the centerline on the Enlock Top Plate.

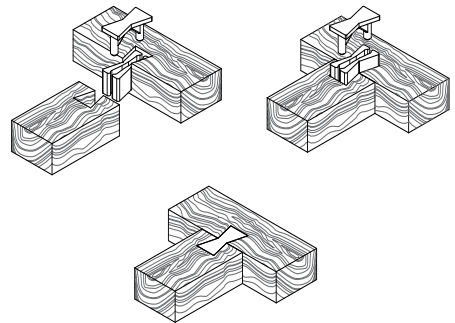

2. Assembly

Very little assembly is required to start working with the Enlock jig. Simply bolt the Support Feet to the jig using the four provided bolts.



3. In order to simplify clamping the Enlock jig to a workbench, fasten the jig to a piece of scrap wood by driving screws through the Support Feet



4. Set the router bit

You must use pattern-style dovetail bits, which include a bearing, for cuts on the Enlock Jig. Use of a bit without a bearing will destroy the jig. Be sure to match the dovetail bit to the size of dovetail key you intend to use. It's critical for the dovetail bit to be set to the correct height in order to achieve the proper fit between the dovetail socket and the dovetail key. When using the small bit, for Enlock10 keys, set the router bit to 21/32-in. by measuring from the base of the router to the tip of the cutter. When using the large bit, for Enlock15 keys, set the router bit to 25/32-in. You must make test cuts in scrap material to insure the depth is correct before making cuts in your project material.



5. Securing your material in the jig

The Enlock Jig uses a simple-to-operate cam clamp to secure your material. The cam clamp allows you to quickly and easily swap pieces in the jig. Set the tension on the clamp by tightening the Clamp Screws on the left and right end of the Clamping Rail. Set the tension so the Cam Clamp Handle moves to a nearly vertical (downward) position when securing material.

When routing dovetail sockets into the edge of a board you'll need to add the Clamp Extension Arm to the Clamp Rail. Depending on the width of your material, you may also need to reposition the Clamp Rail. Due to tolerance build ups between the Clamp Rail and the Clamp Extension Arm, you may want to file the opening in the Clamp Extension Arm so it more easily slides on and off the Clamp Rail.



6. Reposition the Clamp Rail for wide boards by loosening the Clamp Screws and relocating them to holes further away from the Top Plate.



7. Grip boards for edge work by adding the Clamp Extension Arm to the Clamp Rail.



Locating material in the jig

There are a variety of ways to accurately position material in the Enlock jig. The simplest means of positioning material is to make a layout line on the material at what will be the center of the dovetail socket. Locate this line directly under the centerline etched into the Top Plate.



9. You can also position material by locating the edge of the material against the left and right rulers built in to the face of the Enlock Jig. Each ruler indicates the precise distance to the centerline, which is the center of the dovetail socket.

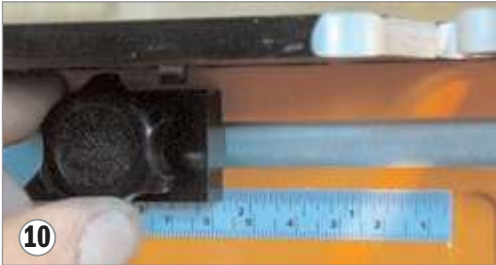

10. When making many repetitive cuts, and to avoid having to put layout lines on every piece, use the Enlock stop system. The stops can be precisely located using the rulers, and you can then simply butt your material against the stops.



11. Position mitered material in the Enlock Jig using the 45-degree Miter Plate.



12. Position the Top Plate

The Top Plate must be correctly positioned to control the depth of the dovetail socket. It's very important to do this step before using the Enlock Jig, or you could cut into the body of the jig with the dovetail bit.

Position and clamp your material in the Enlock Jig. Using an Allen wrench, loosen the four bolts that secure the Top Plate.

Locate the Top Plate by measuring from the edge of the material to the back of the dovetail socket guide.

When using Enlock10 keys set this distance to 9/16-in.

When using Enlock15 keys set it to 3/4-in.

Note that if you change material thickness you must reposition the Top Plate, and test cuts must be made in material the same thickness as your project material.

Test cuts

When making test cuts, be certain your test material is the same thickness as your project material.

In making test cuts you're looking for two things; the correct setting of the dovetail bit, and the correct positioning of the Top Plate.

After setting the bit and Top Plate as indicated above, cut dovetail sockets into two test pieces.



13. Dovetail bit

If the dovetail bit is set too deep, the "neck" of the resulting socket is too narrow and the key won't fit into the opening.



14. If the dovetail bit is not set deeply enough the key will slip into the socket, but the joint won't be able to close.

Adjust the height of the bit until the correct fit is achieved.



Tip: Once you've got a dovetail socket that's correctly cut, label it and keep it for future reference. You can use it to dial in jig settings on future projects.

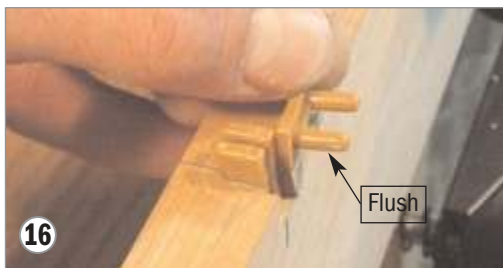

16. Top Plate position

The position of the Top Plate controls how deeply the key will seat into the socket. A correctly cut socket allows the face of the cap to end up flush with, or slightly below, the work surface. Check this by slipping a key into a test socket and holding a cap, upside down, against the top of the key. Check alignment between the underside of the cap and the work surface.

Reposition the Top Plate as necessary to perfect the fit.

Working with the Enlock Jig

The Enlock Jig will assist you with many projects. Here are sample approaches to some standard applications.

Making a face frame

A 2-in wide face frame will accept two Enlock 10 keys. By following the procedure outlined below you can get every dovetail socket without making any layout lines on your boards. Each cut can be accurately made by registering the boards against the stops.

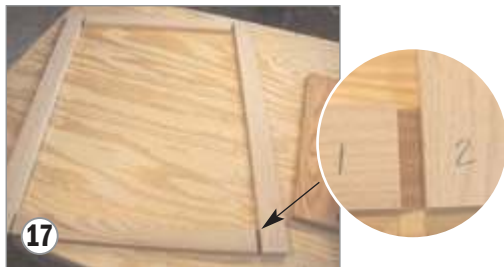

17. With the face frame on the workbench, label the corners. One end of each rail and stile is labeled with a 1, the other end with a 2.



18. Set the right stop to the position of the first dovetail socket. In this case, with a 2-in. wide frame, each socket is 5/8-in. from the edge.



19. Butt the rails labeled with a 1 vertically against the stop and cut a dovetail socket.



20. Add the Clamp Extension Arm and butt the stiles labeled with a 1 horizontally against the stop and cut a dovetail socket.



22. Reposition the stop, **using the same settings as on the right side**, on the left side and repeat the process, placing parts labeled with a 2 against the stop in this position.

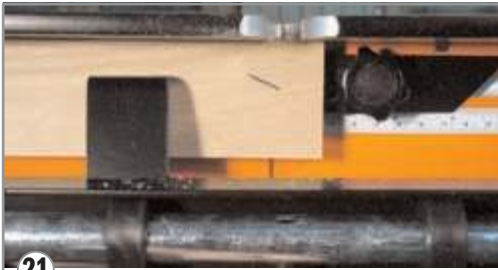

21. Reposition the stop at the 1-3/8-in. position and repeat the process for the second dovetail socket on each rail and stile.



23. Assemble the frame by inserting the keys and tapping the caps in place.



22. Reposition the stop, **using the same settings as on the right side**, on the left side and repeat the process, placing parts labeled with a 2 against the stop in this position.



24. Mitered parts

Place layout lines for locating the dovetail sockets on one miter. Position the piece in the Enlock Jig with one of the layout lines under the centerline in the Top Plate.



25. Slide the Miter Plate against the bottom edge of the mitered piece and lock the Miter Plate in place.



26. From this position, the left and right miters can both be joined. When the first socket has been cut in each piece relocate the Miter Plate for the second socket.



27. Edge-to-edge glue ups

The Enlock Jig allows you to do edge-to-edge glue ups with using any clamps. Mark the locations of the dovetail sockets on the back side of the work pieces. Most edge-to-edge joints require a key every 8-in. Transfer the layout lines to the edges of the pieces.



28. Align the layout lines with the centerline in the Top Plate and cut the dovetail sockets.



29. Apply glue to the edges of the boards, close the joint, and insert the keys and caps.